

# INSTALLATION GUIDE

# NI TB-2709

## PXI Terminal Block for S Series Devices

This installation guide describes how to install and connect signals to the NI TB-2709 terminal block for use with PXI-6123/6133 S Series devices. The TB-2709 can also be used with the PXI-6122/6132 devices to access the first four AI channels.

## Introduction

The TB-2709 is a terminal block assembly consisting of nine SMB connectors and a 14-pin I/O connector. The terminal block assembly connects directly to the front panel of National Instruments PXI-6122, PXI-6123, PXI-6132, and PXI-6133 devices, eliminating the need for an external cable.

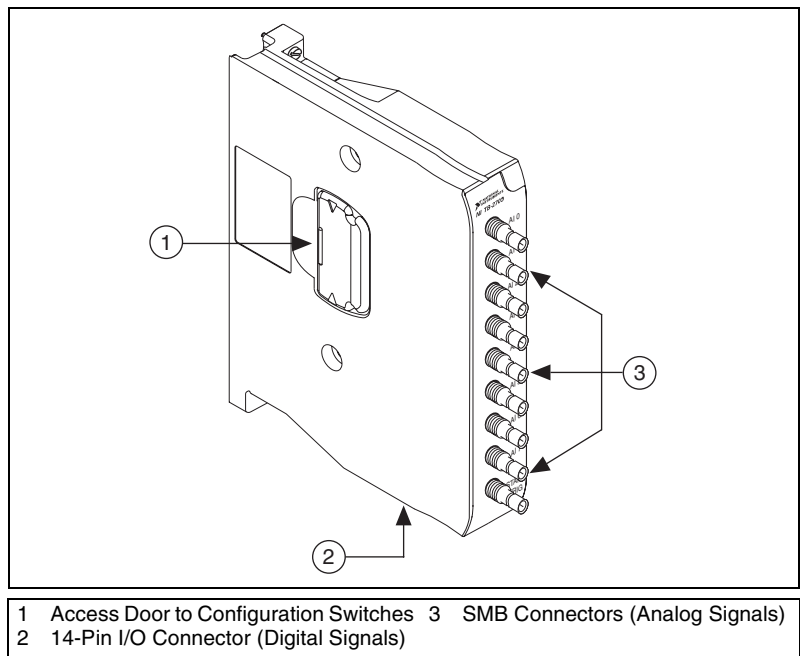

Figure 1. TB-2709 Device View

The nine SMB connectors on the TB-2709 allow you to easily connect analog input signals to your National Instruments device. The 14-pin I/O connector located on the bottom of the TB-2709 allows access to digital signals.



**Caution** The TB-2709 is not designed for input voltages greater than  $42 V_{pk}/60$  VDC, even if you install a voltage divider that reduces the voltage to within the input range of the DAQ device. Input voltages greater than  $42 V_{pk}/60$  VDC can damage the TB-2709, any device connected to it, and the host computer. Overvoltage also can cause an electric shock hazard for the operator. National Instruments is *not* liable for damage or injury resulting from such misuse.

## What You Need to Get Started

---

You need the following to set up and use your terminal block:

- NI TB-2709 Terminal Block Assembly
- NI TB-2709 Installation Guide*
- One of the following:
  - NI PXI-6122
  - NI PXI-6123
  - NI PXI-6132
  - NI PXI-6133
- S Series User Manual*
- Number 1 Phillips screwdriver

## Safety Information

---



**Cautions** Do *not* operate the device in an explosive atmosphere or where there may be flammable gases or fumes.

Do *not* operate damaged equipment. The safety protection features built into this device can become impaired if the device becomes damaged in any way. If the device is damaged, turn the device off and do *not* use it until service-trained personnel can check its safety. If necessary, return the device to National Instruments for service and repair to ensure that its safety is not compromised.

Do *not* operate this equipment in a manner that contradicts the information specified in this document. Misuse of this equipment could result in a shock hazard.

Do *not* substitute parts or modify equipment. Because of the danger of introducing additional hazards, do *not* install unauthorized parts or modify the device. Return the device to National Instruments for service and repair to ensure that its safety features are not compromised.

You *must* insulate all of your signal connections to the highest voltage with which the TB-2709 can come in contact.

Connections, including power signals to ground and vice versa, that exceed any of the maximum signal ratings on the terminal block can create a shock or fire hazard, or can damage any or all of the boards connected to the host computer and the terminal block. National Instruments is *not* liable for any damages or injuries resulting from incorrect signal connections.

Clean the module and accessories by brushing off light dust with a soft non-metallic brush. Remove other contaminants with a stiff non-metallic brush. The unit *must* be completely dry and free from contaminants before returning it to service.

## Installation

The TB-2709 connects directly to the front panel of the PXI DAQ device, as shown in Figure 2.

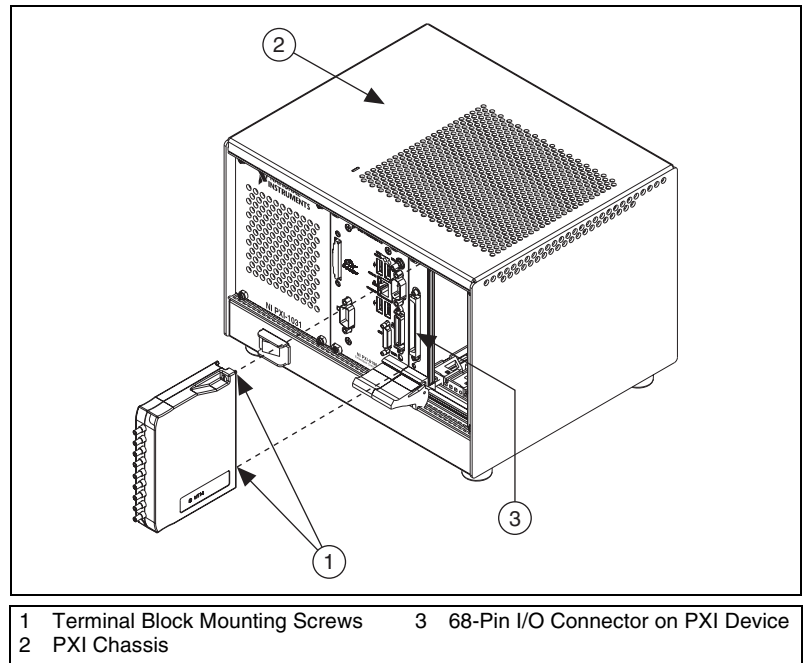

**Figure 2.** Connecting the TB-2709 to an S Series Device

To connect the terminal block to the PXI module I/O connector, refer to Figure 2 as you complete the following steps:

1. Install the PXI module into the chassis and tighten the two module screws. You must install the PXI device before connecting the TB-2709. Refer to the *DAQ Getting Started Guide* for instructions on installing your PXI device.
2. Guide the terminal block onto the PXI module connector.



**Caution** Do not force the terminal block when inserting it into or removing it from the PXI module I/O connector.

3. Tighten the two terminal block mounting screws.

## Signal Descriptions

---

Figure 3 shows the front panel of the TB-2709, and Figure 4 shows the TB-2709 block diagram. Refer to Table 1 for a brief description of each signal available on the TB-2709.

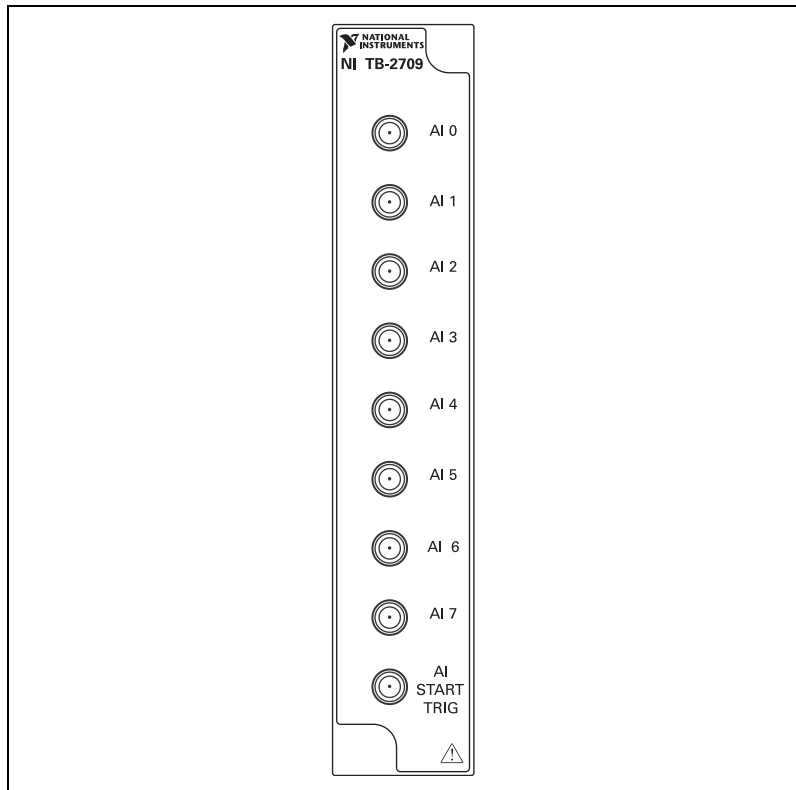

**Figure 3.** NI TB-2709 Front Panel

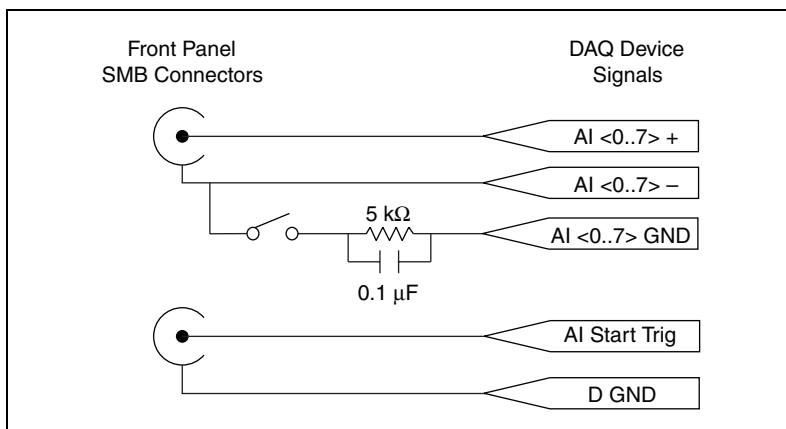

**Figure 4.** NI TB-2709 Block Diagram

**Table 1.** TB-2709 Signal Descriptions

Signal Name	Reference	Direction	Description
AI <0..7>	AI GND	Input	Analog Input channels 0 through 7.
PFI 0/AI Start Trig	D GND	Input	As an input, this pin is a programmable function input (PFI).
		Output	As an output, this pin is the AI Start Trigger signal.

For more detailed descriptions of these signals, refer to the *S Series User Manual*.

Additional signal configuration information is available in Measurement & Automation Explorer (MAX). To access this information in MAX, select your device under **Devices and Interfaces**, and click the **Device Routes** tab.

## Measuring Floating Signals

You can use the TB-2709 to measure floating and ground-referenced analog input signals. To measure floating signal sources, move the switch located under the rubber-sealed door on the enclosure cover for the AI channel you are using to the ON (floating source) switch position. In the floating source switch position, the amplifier negative terminal connects to ground through a 5 kΩ resistor in parallel with a 0.1 μF capacitor. Table 2 shows the TB-2709 switch configuration options.

**Table 2.** Configuration Summary

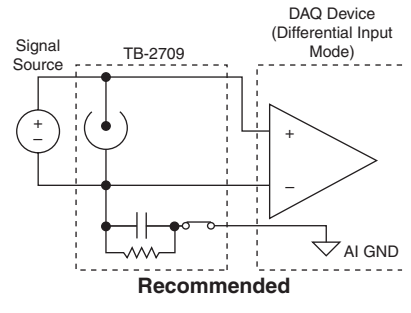
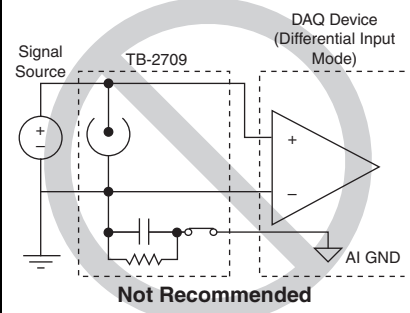
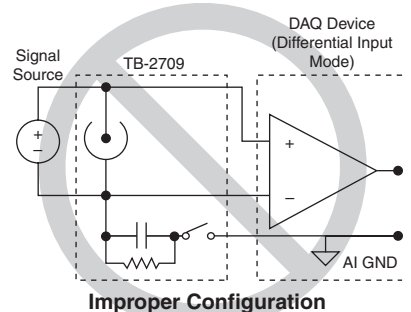
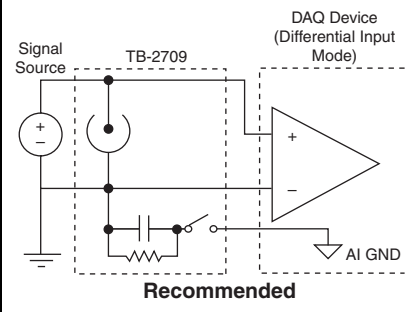
TB-2709 Switch Configuration	Signal Source Types for S Series Devices	
	Floating Source	Ground-Referenced Source
Floating Source	 <p>Recommended</p>	 <p>Not Recommended</p>
Ground-Referenced Source	 <p>Improper Configuration</p>	 <p>Recommended</p>

## Measuring Ground-Referenced Signals

It is possible to set the switch on the TB-2709 to either the floating or ground-referenced source position to measure ground-referenced signals. However, for best results, use the OFF (ground-referenced source) switch position to avoid ground loops. Refer to the *S Series User Manual* for more information on measuring floating and ground-referenced signals.

## Cabling Options

This section describes the cabling options for accessing digital signals on the TB-2709.

A 14-pin connector on the bottom of the TB-2709 provides access to digital I/O signals. Use the MFIT-Pigtail Cable Assembly (part number 194123-01) to access digital signals on the TB-2709. The MFIT-Pigtail Cable Assembly features a 14-pin I/O connector on one end and pigtail

conductors on the other end. The pigtail conductors on the cable assembly can be used to terminate digital signals to the connector(s) your application requires. Figure 5 and Table 3 list the pin assignments and wiring information necessary for connecting the TB-2709 to DIO signals.

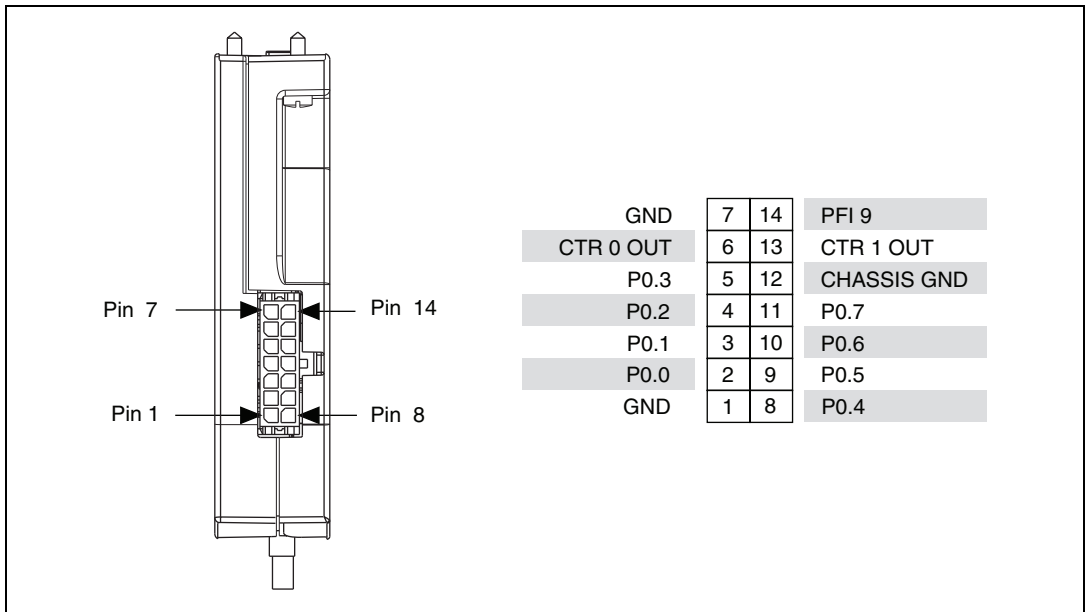

**Figure 5.** 14-Pin Digital I/O Connector

**Table 3.** TB-2709 Wiring Information for 14-Pos MFIT-Pigtail Cable Assembly (Part Number 194123-01)

Pin Number	Wire Color	Signal Name
1	Black	D GND
1	Brown	D GND
2	Red	P0.0
3	Orange	P0.1
4	Yellow	P0.2
5	Green	P0.3
6	Blue	CTR 0 OUT
7	Violet	D GND
7	Gray	D GND
8	White	P0.4

**Table 3.** TB-2709 Wiring Information for 14-Pos MFIT-Pigtail Cable Assembly (Part Number 194123-01) (Continued)

Pin Number	Wire Color	Signal Name
9	White/Black	P0.5
10	White/Brown	P0.6
11	White/Red	P0.7
12	Drain Wire	CHASSIS GND
13	White/Orange	CTR 1 OUT
14	White/Yellow	PFI 9

Table 4 lists the National Instruments cables available for connecting the TB-2709 to both analog and digital user signals.

**Table 4.** TB-2709 Cabling Options

Cable	Length	Part Number
SMB-100, SMB Female to BNC Female Coaxial, 50 $\Omega$	0.6 m	763389-01
SMB110, SMB to BNC Male Coaxial, 50 $\Omega$	1 m	763405-01
14-Pos MFIT-Pigtail Cable Assembly	1 m	194123-01

## Specifications

This section lists the specifications of the TB-2709. These specifications are typical at 25 °C unless otherwise specified.

### Input/Output

Refer to the documentation for your PXI-6123/6133 or PXI-6122/6132 S Series device to determine the input/output specifications for your application.



**Caution** Do not apply an input voltage greater than 42 V<sub>pk</sub>/60 VDC to the TB-2709. Input voltages greater than 42 V<sub>pk</sub>/60 VDC can damage the TB-2709 and any device connected to it, including the host computer. Overvoltage can also cause an electric shock hazard for the operator. National Instruments is not liable for damage or injury resulting from such misuse.



# Physical

## Dimensions

Height..... 10.7 × 8.6 × 2.0 cm  
(4.2 × 3.4 × 0.8 in.)

Weight..... 144.6 g (5.1 oz)

## I/O connectors

68-position SCSI-II type ..... 1, female

SMB jacks ..... 9

14-pin auxiliary connector ..... One, Molex 14-pin microfit connector

# Shock and Vibration

Operational shock ..... 30 g peak, half-sine, 11 ms pulse  
(Tested in accordance with IEC-60068-2-27. Test profile developed in accordance with MIL-PRF-28800F.)

## Random vibration

Operating ..... 5 to 500 Hz, 0.3 g<sub>rms</sub>

Nonoperating ..... 5 to 500 Hz, 2.4 g<sub>rms</sub>  
(Tested in accordance with IEC-60068-2-64. Nonoperating test profile exceeds the requirements of MIL-PRF-28800F, Class 3.)

# Environment

The NI TB-2709 is intended for indoor use only.

Operating temperature..... 0 to 55 °C

Storage temperature ..... –20 to 70 °C

Relative humidity ..... 10 to 90% noncondensing

Pollution Degree ..... 2

## Safety

This product is designed to meet the requirements of the following standards of safety for electrical equipment for measurement, control, and laboratory use:

- IEC 61010-1, EN 61010-1
- UL 61010-1, CSA 61010-1



**Note** For UL and other safety certifications, refer to the product label, or visit [ni.com/certification](http://ni.com/certification), search by model number or product line, and click the appropriate link in the Certification column.

## Waste Electrical and Electronic Equipment (WEEE)



**EU Customers** At the end of their life cycle, all products *must* be sent to a WEEE recycling center. For more information about WEEE recycling centers and National Instruments WEEE initiatives, visit [ni.com/environment/weee.htm](http://ni.com/environment/weee.htm).

## Where to Go for Support

---

The National Instruments Web site is your complete resource for technical support. At [ni.com/support](http://ni.com/support) you have access to everything from troubleshooting and application development self-help resources to email and phone assistance from NI Application Engineers.

A Declaration of Conformity (DoC) is our claim of compliance with the Council of the European Communities using the manufacturer's declaration of conformity. This system affords the user protection for electronic compatibility (EMC) and product safety. You can obtain the DoC for your product by visiting [ni.com/certification](http://ni.com/certification). If your product supports calibration, you can obtain the calibration certificate for your product at [ni.com/calibration](http://ni.com/calibration).

National Instruments corporate headquarters is located at 11500 North Mopac Expressway, Austin, Texas, 78759-3504. National Instruments also has offices located around the world to help address your support needs. For telephone support in the United States, create your service request at [ni.com/support](http://ni.com/support) and follow the calling instructions or dial 512 795 8248. For telephone support outside the United States, contact your local branch office:

Australia 1800 300 800, Austria 43 662 457990-0,  
Belgium 32 (0) 2 757 0020, Brazil 55 11 3262 3599,  
Canada 800 433 3488, China 86 21 5050 9800,  
Czech Republic 420 224 235 774, Denmark 45 45 76 26 00,

Finland 385 (0) 9 725 72511, France 33 (0) 1 48 14 24 24,  
Germany 49 89 7413130, India 91 80 41190000, Israel 972 3 6393737,  
Italy 39 02 413091, Japan 81 3 5472 2970, Korea 82 02 3451 3400,  
Lebanon 961 (0) 1 33 28 28, Malaysia 1800 887710,  
Mexico 01 800 010 0793, Netherlands 31 (0) 348 433 466,  
New Zealand 0800 553 322, Norway 47 (0) 66 90 76 60,  
Poland 48 22 3390150, Portugal 351 210 311 210, Russia 7 495 783 6851,  
Singapore 1800 226 5886, Slovenia 386 3 425 42 00,  
South Africa 27 0 11 805 8197, Spain 34 91 640 0085,  
Sweden 46 (0) 8 587 895 00, Switzerland 41 56 2005151,  
Taiwan 886 02 2377 2222, Thailand 662 278 6777,  
Turkey 90 212 279 3031, United Kingdom 44 (0) 1635 523545

National Instruments, NI, ni.com, and LabVIEW are trademarks of National Instruments Corporation. Refer to the *Terms of Use* section on [ni.com/legal](http://ni.com/legal) for more information about National Instruments trademarks. Other product and company names mentioned herein are trademarks or trade names of their respective companies. For patents covering National Instruments products, refer to the appropriate location: **Help»Patents** in your software, the `patents.txt` file on your CD, or [ni.com/patents](http://ni.com/patents).